

## DPL ISLA 1185

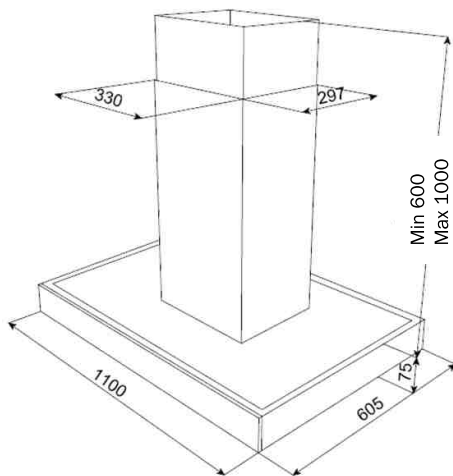

## CHARACTERISTICS

- Horizontal Hood with **HL** family look
- 110 cm width
- Rim- extraction
- Touch control with white display
- LED 4x3W lamps
- 3 speeds + Intensive
- Stop delay timer
- Filter saturation indicator
- 1 Stainless steel panel Aluminium filters
- Double turbine motor
- Reduction 150/120mm included
- European plug included
- Optional recirculation mode (SET 1/T)
- Annual Energy Consumption (AEC<sub>hood</sub>) kWh/a 49,3
- Energy Efficiency class A
- Fluid Dynamic Efficiency (FDE<sub>hood</sub>) 32,1
- Fluid Dynamic Efficiency class A
- Light Efficiency (Lehood) lux/Watt 58,3
- Lighting Efficiency class A
- Grease Filtering Efficiency (GFE<sub>hood</sub>) % 75,9
- Grease Filtering Efficiency class C
- Air flow (Qmin) m<sup>3</sup>/h 331
- Air flow (Qmax) m<sup>3</sup>/h 629
- Air flow (Qboost) m<sup>3</sup>/h 782
- Noise (LwA) Min Speed dB 54
- Noise (LwA) Max Speed dB 66
- Noise (LwA) Boost Speed dB 69
- Off mode Power (Po) W 0
- Standby Power (Ps) W 0,74
- Energy Efficiency Index (EEI<sub>hood</sub>) 50,1
- Time increase actor (f) 0,8
- Air flow at best efficiency point (Qbep) m<sup>3</sup>/h 346
- Air pressure at best efficiency point (Pbep) Pa 464
- Electric power input at best efficiency point (Wbep) W 139
- Nominal power of the lighting system (WL) W 12
- Average illumination of the lighting system on the cooking surface (Emiddle) Lux 700

| MODEL     | TKI CODE | EAN CODE      |
|-----------|----------|---------------|
| BODY      | 40483172 | 8421152145777 |
| STRUCTURE | 40483173 | 8421152145784 |